

LONG RADIUS NOZZLES

Technical Data

ISO 5167-3,2003(E) standard

Two long radius type

high-ratio nozzles ($0.25 \leq \beta \leq 0.8$)

low-ratio nozzles ($0.20 \leq \beta \leq 0.5$)

Flange wafer type.

Welded-in type.

Welded-in with holding ring type.

Material: A105, stainless steel. Others on request.



Long Radius Series

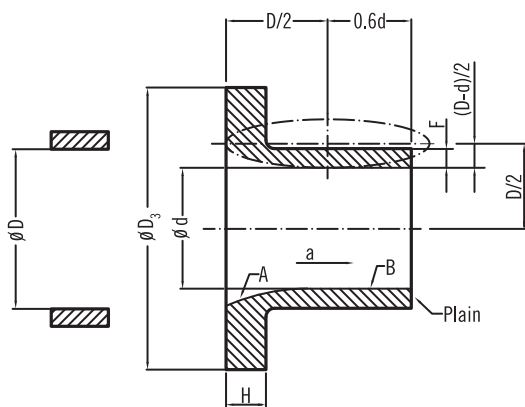

High ratio $0.25 \leq \beta \leq 0.8$

* A: convergent section
B: throat

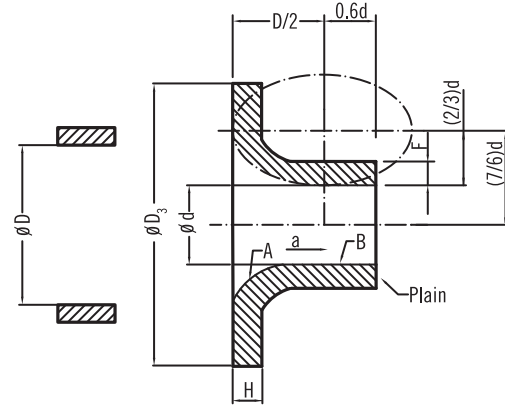

Low ratio $0.2 \leq \beta \leq 0.5$

Flow Nozzle Series

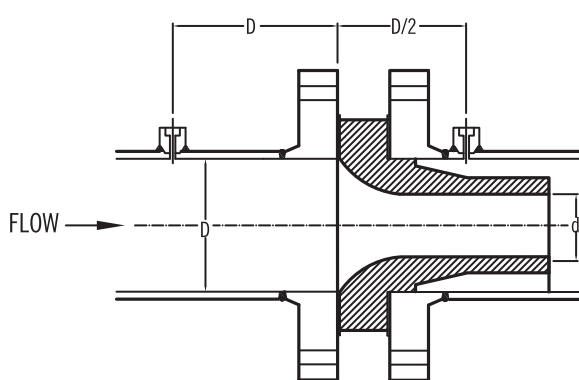

Wafer Type-Typical Nozzle
Model: NF

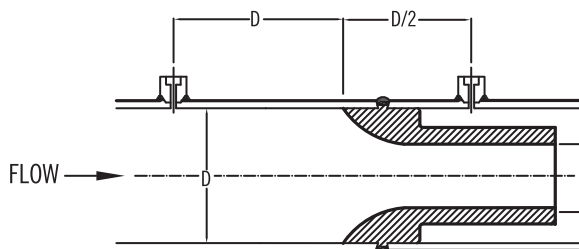

Welded-In Type-Flow Nozzle
Model: NW

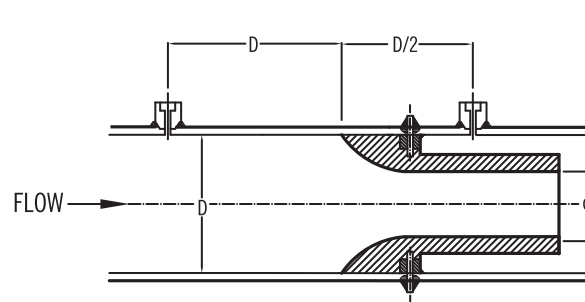

Welded-In with Holding Ring-Type
Model: NWR

Ordering Information

Individual Specification		Requirement	Requirement
General			
1	P & ID No.		
2	Line No. / Vessel No.		
3	Line Size		
4	Sched No.		
5	Accuracy		
6	FCFCs Painting or Makers Painting STD		
Flow Nozzle			
7	Nozzle Type		
8	Applied Code or Standard		
9	Nozzle Material		
10	Meter Run		
11	Bore / Diameter Ratio (d/D)		
12	Tap Type		
13	Tap Conn.		
Operating Condition			
14	Fluid & State		
15	Flow Rate: Norm.	Max. (T/Hr)	
16	Press. Norm.	Max. (kg/cm ² G)	
17	Temp. Norm.	Max. (°C)	
18	Specific Gravity / Density		
19	Molecular Weight		
20	Viscosity Range (Cp)		
21	Compression Factor		
22	Ratio of Spec. Heat (Cp/Cv)		
23	Measuring Range (T/H)		
24	Diff. Press. Range (mmH ₂ O)		
25	Total Length		
26	Q'ty		
27	Tag No.		

* Please fill in above block on request.