

3-PIECE BALL VALVES – Without Mounting Pad

N-3T – THREAD **N-3B – BUTT WELD** **N-3S – SOCKET WELD**

Technical Data

Full Port, 3 piece type

Material: Wetted parts ASTM A351 CF8M / 316

Connection Size: ¼" (8mm), ⅜" (10mm), ½" (15mm), ¾" (20mm), 1" (25mm), 1¼" (32mm), 1½" (40mm), 2" (50mm), 2½" (65mm), 3" (80mm), 4" (100mm)

Connection Type: Thread, Socket weld and Butt weld ends available

Locking Device: Valve operated locking in open or closed position

Working Temperature Limited: -20°F ~ 350°F (-5°C ~ 175°C)

Working Pressure Limited: 1000psi (70kg/cm²) for ¼"~1"; 800psi (56kg/cm²) for 1¼"~2"; 600psi (42kg/cm²) for 2½"~4"

Valves inspected and tested according to **API 598 standard**.



Dimensions

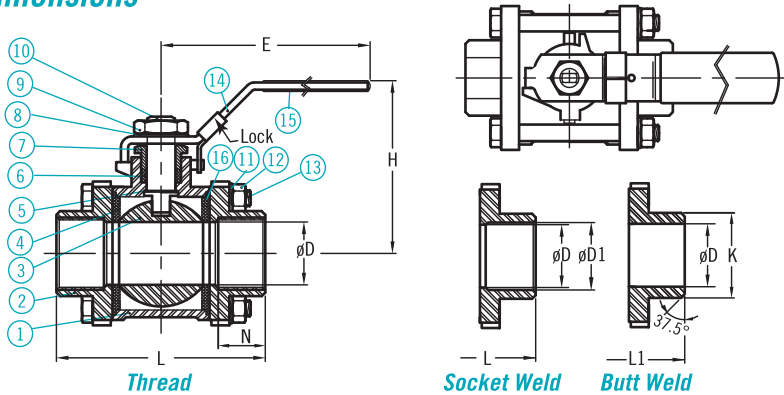

unit=mm

mm	Size inch	ØD±0.5	L±2.0	H±3.0	E±3.0	ØD1±0.5	L1±2.0	Wt/Kg	N±2.0	CV Factor	TORQUE Inch/Lbs	K±0.5
08	¼	11.6	55	52	103	14.2	60	0.36	10.5	6.6	70	18
10	⅜	12.7	60	52	103	17.7	60	0.34	12.5	7.9	70	18
15	½	15	62.7	55	103	21.8	70	0.43	20	11.2	80	22
20	¾	20	68	63	103	27.2	85	0.64	21	21	110	27.5
25	1	25	79.6	70	135	34	95	0.89	21	35	160	34.5
32	1¼	32	90.6	76	135	42.7	110	1.42	27.5	57	220	40.5
40	1½	38	106.7	89	180	48.8	120	2.07	26.5	80	400	47
50	2	50	126.5	97	180	61.2	142	3.02	31	150	450	60.5
65	2½	65	162	143	260	74	166	8.3	28	265	650	76
80	3	80	184	152	260	90	182	12.4	33.5	415	930	92
100	4	100	228	187	400	115.6	227	21.4	41	780	1100	116

Parts List

Item	Parts Name	Material
1	Body	ASTM A351 CF8M / 316
2	Cap	ASTM A351 CF8M / 316
3	Ball	ASTM A351 CF8M / 316
4	Seat	PTFE / RPTFE
5	Thrust Packing	PTFE
6	Stem Packing	PTFE
7	Gland Nut	AISI 304
8	Stem Washer	AISI 304
9	Stem Nut	AISI 304
10	Stem	AISI 316
11	Bolt Washer	AISI 304
12	Nut	AISI 304
13	Bolt	AISI 304
14	Handle	AISI 304
15	Plastic Cover	Plastic
16	Gasket	PTFE

Pressure–Temperature

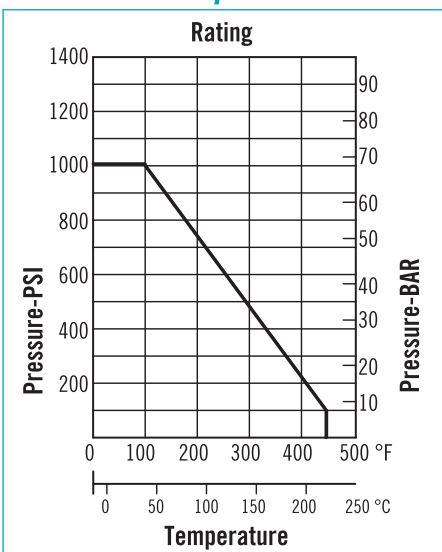

Ordering Information

N-3	Code	Model
	T	Thread
	B	Butt Weld
	C	Socket Weld
	Code	Body Material
	S	CF8M / SS316
	Code	Connection Size
	(A) ¼" (B) ⅜" (C) ½" (D) ¾" (E) 1" (F) 1¼"	
	(G) 1½" (H) 2" (I) 2½" (J) 3" (K) 4"	
N-3		Complete Ordering Code